

ACCESSORIES



BYF

IN LINE DUCT FILTERS 200 - 315

As BDTX fans are used oily or dirty places, BYFs should be added. These filters hold oil to prevent motors to get harmed, impellers to get heavy and unbalanced in time. BYF is designed to be mounted inside duct fans.

TYPE	A	B	C	D	E
BYF 200	135	195	270	335	20
BYF 250	145	245	270	335	20
BYF 315	175	290	280	345	20

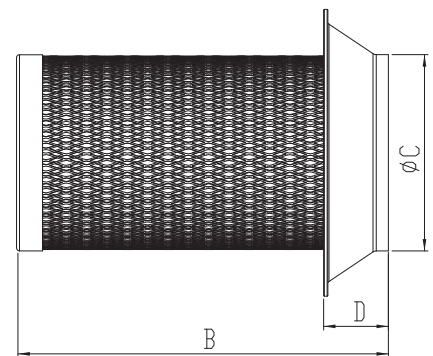
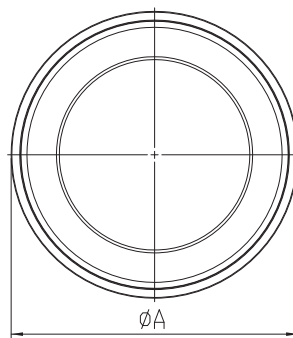

BYEB

CIRCULAR FLEXIBLE FLANGES 250 - 1000

BYEB has flexible connections and is made of galvanized sheet material and has a neoprene fabric cover between 2 flanges.

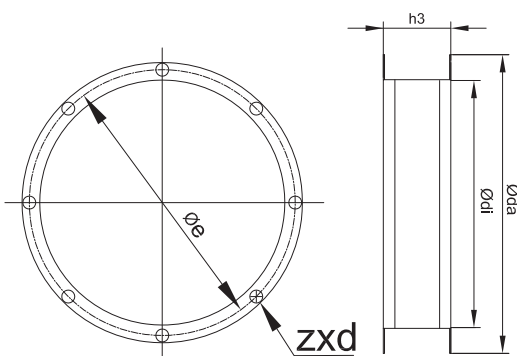

TYPE	Øda	Øe	Ødi	h3	z x d
BYEB 250	316	290	256	155	8 x Ø9,5
BYEB 280	345	320	286	155	8 x Ø9,5
BYEB 315	382	356	322	155	8 x Ø9,5
BYEB 355	421	395	361	155	8 x Ø9,5
BYEB 400	475	438	402	155	12 x Ø9,5
BYEB 450	524	478	453	155	12 x Ø9,5
BYEB 500	577	541	505	155	12 x Ø9,5
BYEB 560	652	605	569	155	16 x Ø12
BYEB 630	723	674	638	155	16 x Ø12
BYEB 710	802	751	712	155	16 x Ø12
BYEB 800	890	837	797	155	24 x Ø12
BYEB 900	1000	934	894	160	24 x Ø12
BYEB 1000	1090	1043	1003	165	24 x Ø12